



# ICBO Evaluation Service, Inc.

5360 WORKMAN MILL ROAD • WHITTIER, CALIFORNIA 90601-2299

A subsidiary corporation of the International Conference of Building Officials

Accredited by the  
American National Standards Institute

## EVALUATION REPORT

Copyright © 2000 ICBO Evaluation Service, Inc.

ER-5827

Issued October 1, 2000

Filing Category: FASTENERS—Wood Hangers and Framing Members (066)

### JOIST POCKET LINER™

JPL, LLC  
7201 WEST FRANKLIN ROAD  
BOISE, IDAHO 83709

#### 1.0 SUBJECT

Joist Pocket Liner.

#### 2.0 DESCRIPTION

##### 2.1 General:

The Joist Pocket Liner™ (JPL) is a polyethylene product manufactured by an injection molding process. The purpose of the JPL is to form a pocket (block out) in a concrete foundation wall, to support the end of an engineered wood I-joist or a conventional wood joist. The pocket liner creates a moisture barrier and provides a vertical support system for joists in a concrete foundation wall.

JPLs are produced in different depths and widths to accommodate various sizes of engineered wood I-joists and conventional wood joists. The pocket liners are available in the following sizes:

2 inches wide by  $8\frac{1}{16}$  inches high by 2 inches deep (51 mm by 205 mm by 51 mm)

2 inches wide by  $10\frac{7}{16}$  inches high by 2 inches deep (51 mm by 265 mm by 51 mm)

$2\frac{1}{2}$  inches wide by  $10\frac{7}{16}$  inches high by 2 inches deep (63.5 mm by 265 mm by 51 mm)

The JPL is an alternative method of construction to that specified in Section 2318.4 of the 1997 *Uniform Building Code*™ (UBC), Sections 1715.1 and 2304.9.3 of the 2000 *International Building Code*® (IBC), and Section R602.3 of the 2000 *International Residential Code*™ (IRC).

Please see Figure 1 for additional details.

##### 2.2 Installation:

The JPL is placed in the concrete foundation wall, prior to pouring of the concrete, and spaced horizontally to be consistent with the joist center-to-center spacing. The pocket liners are set vertically so the top of the joist is level with the top of the foundation sill plate, and with the open front against the inside face of the inside concrete forms (forming the inside

face of the foundation walls). The pocket liners are fastened to the wood forms with preinstalled nails at the appropriate elevation and on-center spacing. Following removal of the concrete forms, the top knockout is removed with a hammer and the joist is placed into the JPL. All other I-joist installation details must be in accordance with the respective I-joist manufacturer's recommendations.

##### 2.3 Identification:

The JPL is identified with the name "JOIST POCKET LINER" on the inside face of the pocket liner, and with the ICBO ES evaluation report number (ICBO ES ER-5827).

#### 3.0 EVIDENCE SUBMITTED

Descriptive literature, testing laboratory material analysis, installation details, and information regarding the manufacturing process.

#### 4.0 FINDINGS

**That the Joist Pocket Liner™ described in this evaluation report is an alternative method of construction to that specified in the 1997 *Uniform Building Code*™, the 2000 *International Building Code*® and the 2000 *International Residential Code*™, subject to the following conditions:**

- 4.1 The product is identified and installed in accordance with the details noted in this report and the manufacturer's installation instructions.
- 4.2 The product is limited to installations in concrete stem walls, a maximum of 48 inches (914 mm) in height, unless an engineered design is submitted to the local code official, taking into account positive attachment of the floor framing to the concrete wall and lateral support provisions for the wall by the floor framing.
- 4.3 JPL, LLC, is responsible for obtaining a letter from specific I-joist manufacturers, indicating the acceptability of the Joist Pocket Liner. The letter must be made available to the local building jurisdiction upon request.

This report is subject to re-examination in one year.

*Evaluation reports of ICBO Evaluation Service, Inc., are issued solely to provide information to Class A members of ICBO, utilizing the code upon which the report is based. Evaluation reports are not to be construed as representing aesthetics or any other attributes not specifically addressed nor as an endorsement or recommendation for use of the subject report.*

*This report is based upon independent tests or other technical data submitted by the applicant. The ICBO Evaluation Service, Inc., technical staff has reviewed the test results and/or other data, but does not possess test facilities to make an independent verification. There is no warranty by ICBO Evaluation Service, Inc., express or implied, as to any "Finding" or other matter in the report or as to any product covered by the report. This disclaimer includes, but is not limited to, merchantability.*

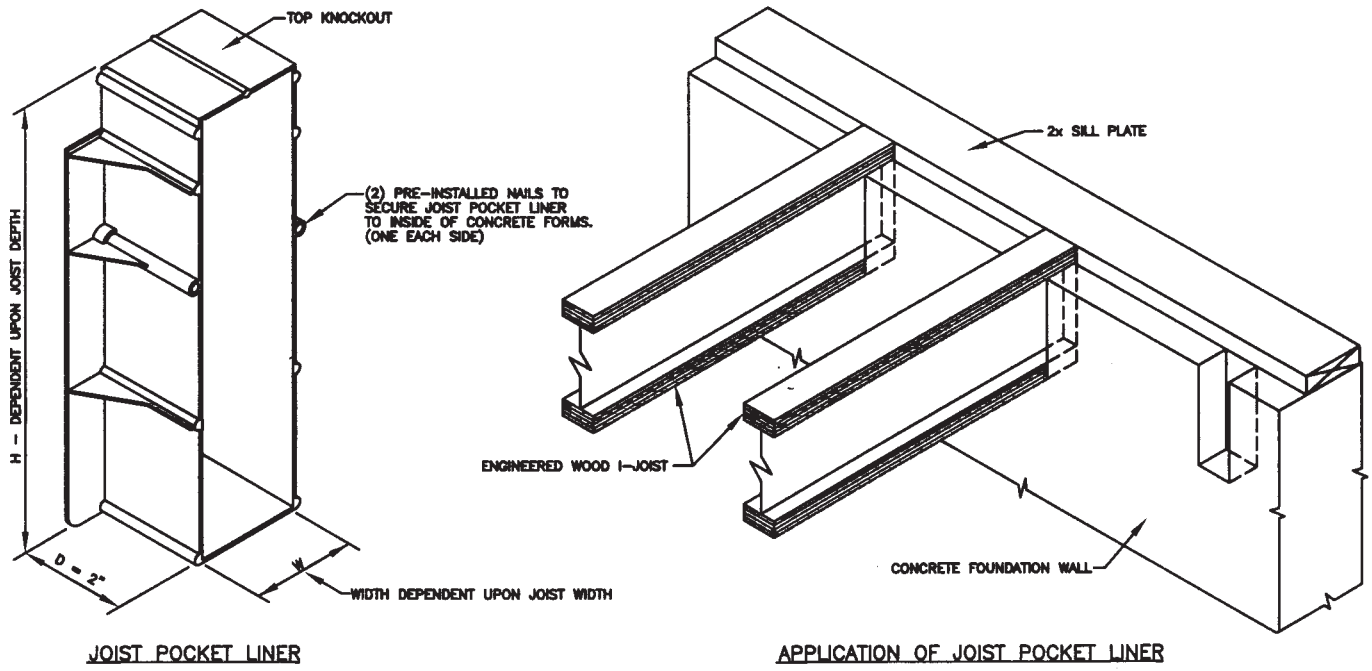

FIGURE 1—INSTALLATION IN A CONCRETE STEM WALL